

Camshaft Roller Follower

Special Tool(s)

 ST1330-A	Compressor, Valve Spring 303-581 (T97T-6565-A)
---	---

Material

Item	Specification
Motorcraft® SAE 5W-30 Premium Synthetic Blend Motor Oil XO-5W30-QSP (US); Motorcraft® SAE 5W-30 Super Premium Motor Oil CXO-5W30-LSP12 (Canada); or equivalent	WSS-M2C929-A

Removal and Installation

1. Remove the fuel rail. For additional information, refer to [Section 303-04A](#).
2. Remove the LH and RH valve covers. For additional information, refer to [Valve Cover — RH](#) and [Valve Cover — LH](#) in this section.
3. Rotate the crankshaft until the camshaft for the cylinder being serviced is at base circle.

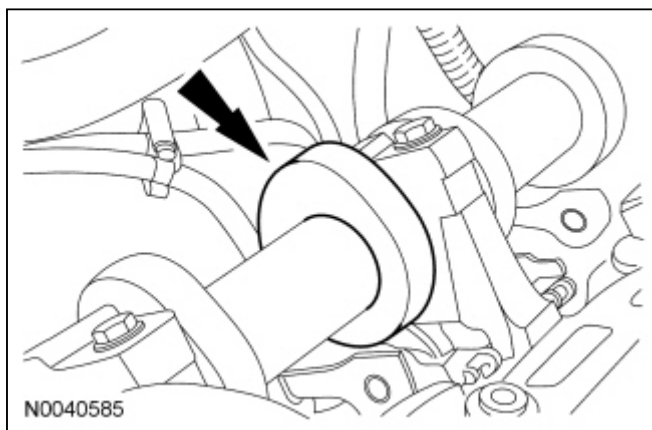

4. **NOTE:** Mark the position of the camshaft roller followers so they can be installed in their original positions.

Using the Valve Spring Compressor, remove the camshaft roller followers.

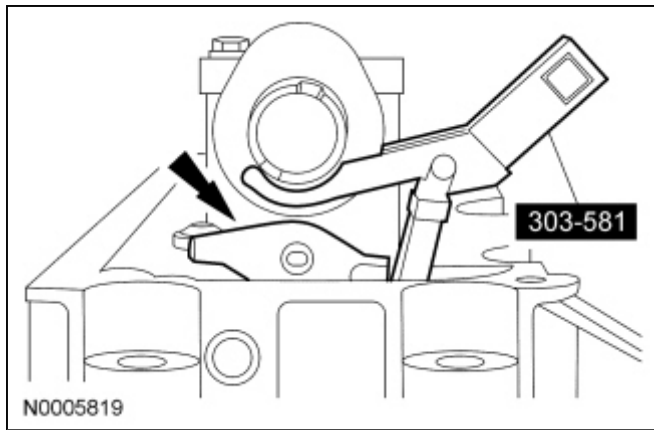

5. **NOTE:** The camshaft roller followers must be installed in their original positions.

NOTE: Lubricate the camshaft roller followers with clean engine oil.

To install, reverse the removal procedure.
